



ROBUR

1

GRILLE GATE TYPE 950 - 2019



GRILLE GATE TYPE 950

Gate

The main usage area for Robur's Grille Gate is as protection against unauthorized admission daytime, when the Strongroom door is in open position.

The Grille Gate is designed to fit Robur's Strongroom doors.

Robur's Grille Gate can be produced in other widths on special order.

Description

Robur's Grille Gate is manufactured in steel.

The Grille Gate is delivered including door closer and consol.

Locking

Mechanical lock

To be opened with key from the outside and handle from the inside.

Option: Electronic release 24V

Finish

Painted in grey RAL 9006.

Installation

The frame profiles are to be mounted on the inside of the frame of the Strongroom door by MC6S M6 screws. The holes will be covered by plastic plugs. The frame of Robur's Strongroom door is prepared for mounting of the Grille Gate.

Installation in existing wall

As per sketch, observe the overlap shall be 12 mm (± 2 mm).

Insight protection

The Grille Gate can on special order be fitted with plastic glass protection against viewing through the Grille Gate.

Dimensions and weight

Height	1900 mm
Width	950 mm
Total width	1078 mm incl. frame profiles
Weight	44 kilo

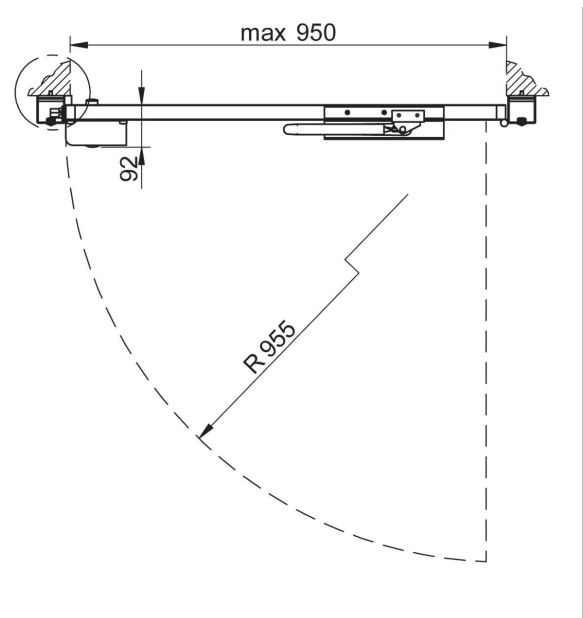
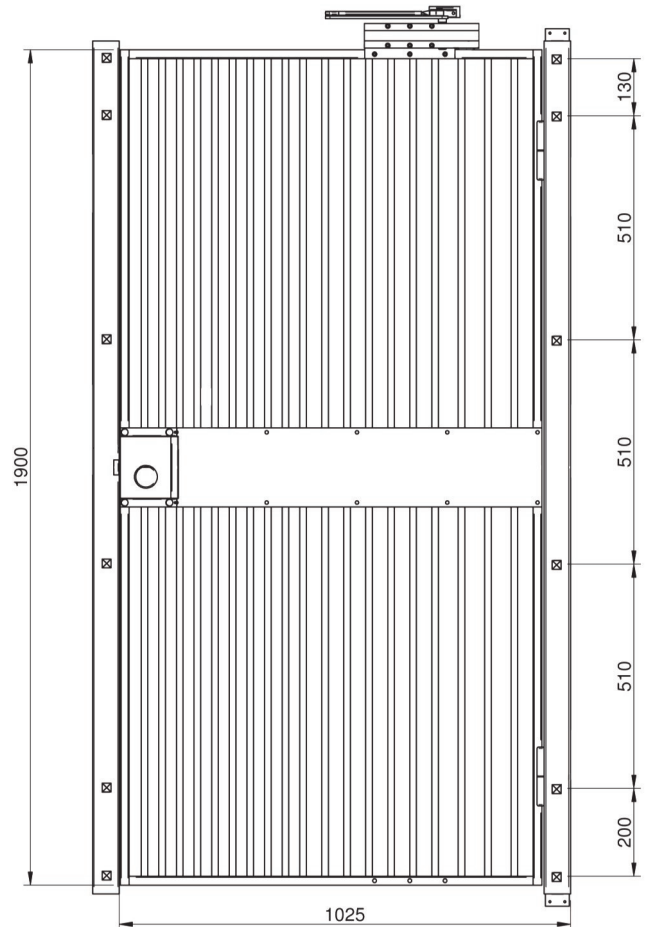

We reserve the right to alter the specification without prior notice.



Head office

Robur Safe AB

Lundbyvägen 8
SE-311 68 SLÖINGE
Phone: +46 346 260 260
Fax: +46 346 260 222

info@robursafe.com

www.robursafe.com