



ROBUR

1

GRILLE GATE TYPE 950 - 2019



GRILLE GATE TYPE 950

Gate

The main use for Robur's Grille Gate is as protection against unauthorized admission daytime, when the Strongroom door is in an open position.

The Grille Gate is designed to fit Robur's Strongroom doors.

Robur's Grille Gate can be produced in other widths on special order.

Description

Robur's Grille Gate is manufactured in steel bars.

The Grille Gate is delivered including door closer and consol.

The frame consists of two square profiles 60x60mm.

Locking

Mechanical lock

To be opened with key from the outside and handle from the inside.

Electronic release 24V

Finish

Painted in grey RAL 9006.

Installation

The frame profiles are to be mounted on the inside of the frame of the Strongroom door by 12 M6 screws.

The holes will be covered by plastic plugs.

The frame of Robur's Strongroom door is prepared for mounting of the Grille Gate.

Installation in existing wall

As per sketch, observe the overlap shall be 12 mm (± 2 mm).

Dimensions and weight

Height 1900 mm

Clear Width 950 mm

Total width 1078 mm incl. frame profiles

Weight with mechanical lock: 43kg

Weight with electronic release: 46kg

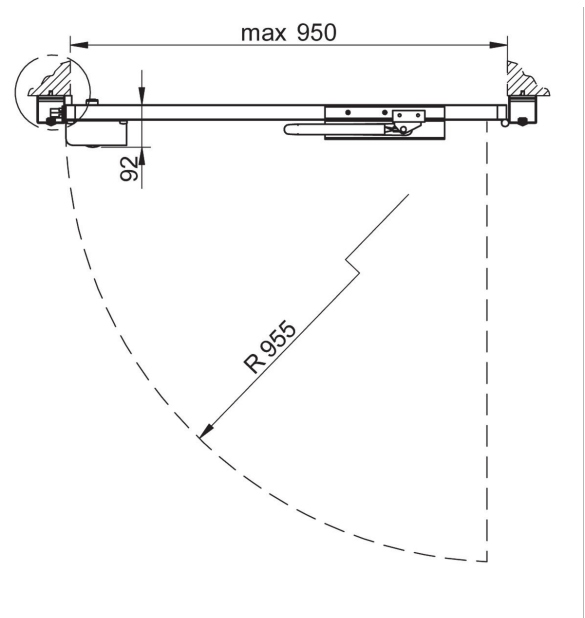
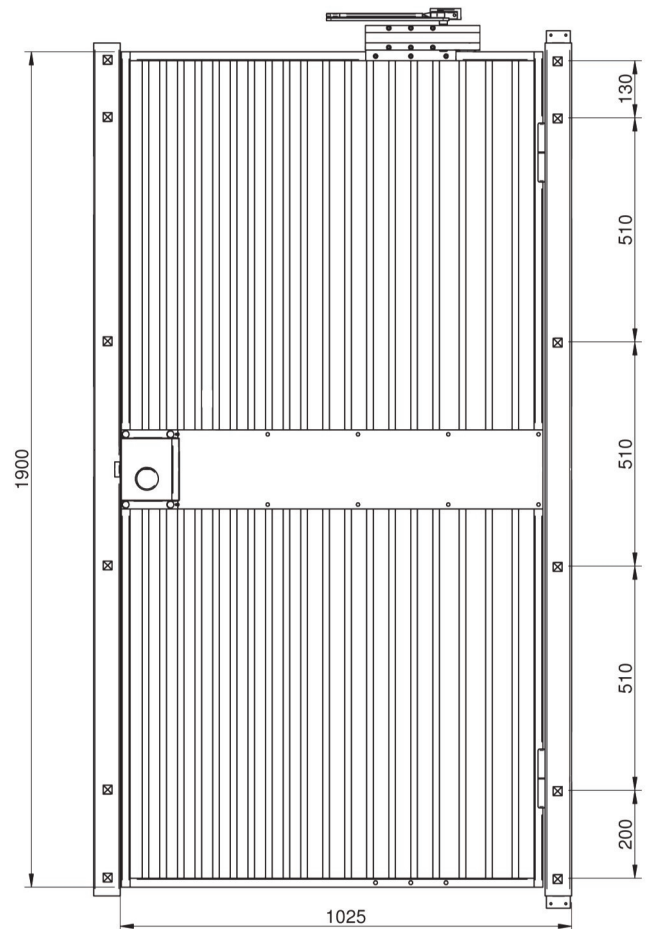

We reserve the right to alter the specification without prior notice.



Head office

Robur Safe AB

Lundbyvägen 8
SE-311 68 SLÖINGE
Phone: +46 346 260 260
Fax: +46 346 260 222

info@robursafe.com

www.robursafe.com