



Vault door Grade I

The door can be cast or delivered to a prefabricated vault where for example: weapons, explosives, medicines, jewellery, watches and other valuable are stored.



The vault door is primed finish as standard.



Standard equipped with a changeable key lock. Electronic combination lock and/or one extra lock on special order.

On special order, the door can be equipped with special regulations for emergency opening (inside or outside). An emergency opening lock per mounted lock.



Provided as standard with alarm cabling between the door and its frame through one of the hinges. One door stop holder is delivered with the door as standard.

The door is prepared for a grille gate as standard.



Fire protected according to EI90.



Burglary protection certified by SBSC according to the European standard EN 1143-1.

WEIGHT AND MEASUREMENTS

RVD Grade I	
Standard clear opening measure H * W mm	2000 * 900
Frame	The frame is designed for 150 mm wall thickness.
Weight kg	420

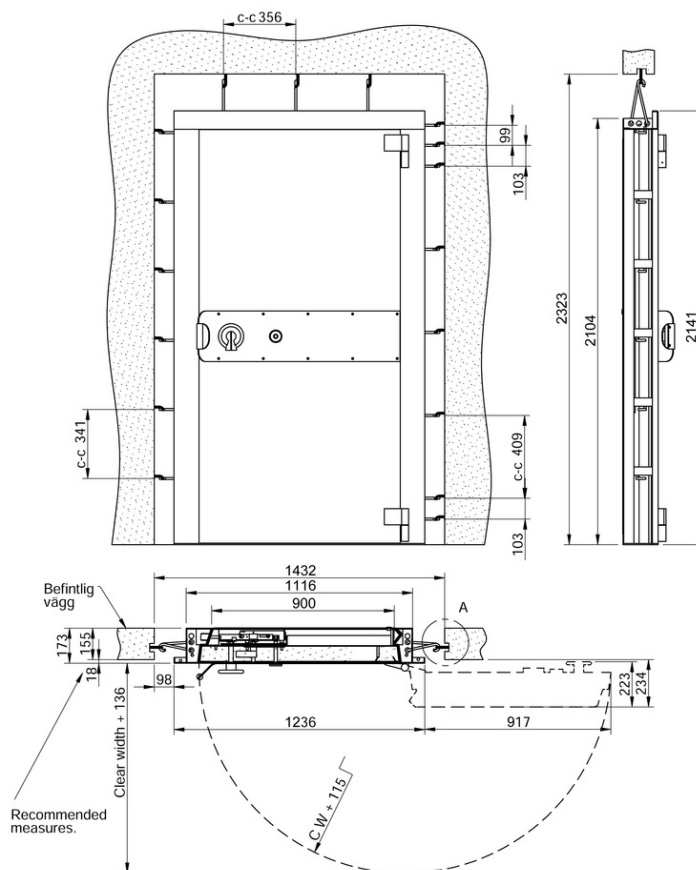

HANGING OF DOOR AND GATE:

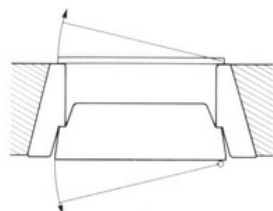

fig. 1. Door - right hung
Gate - left hung

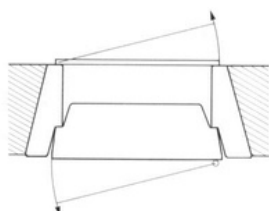

fig. 2. Door - right hung
Gate - right hung

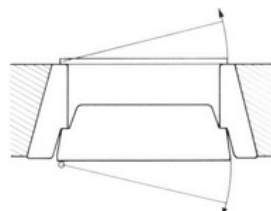

fig. 3. Door - left hung
Gate - right hung

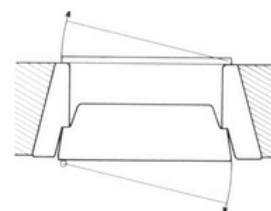

fig. 4. Door - left hung
Gate - left hung

We reserve the right to alter the specification without prior notice.



Head office:
Robur Safe AB
Lundbyvägen 8
311 68, Slöinge
Sweden

+ 46 346 260 260
info@robursafe.com
www.robursafe.com